



Promat® MODULAR FLOOR



Product description

Promat® Modular Floor, the flooring system of the Promat® Modular Interior Solutions, offers an acoustic insulated solution for Marine flooring. The system comprises of a steel frame, supported by adjustable and decoupled rubber feet, on which a variety of boards, such as PROMARINE®-PX1 can be installed.





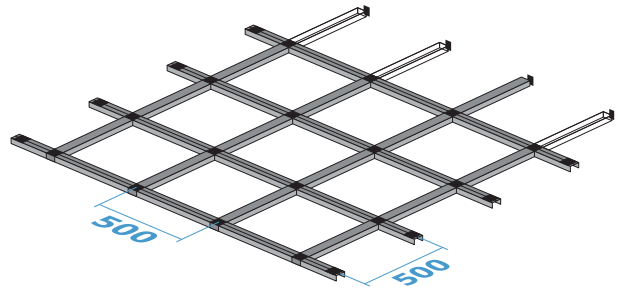
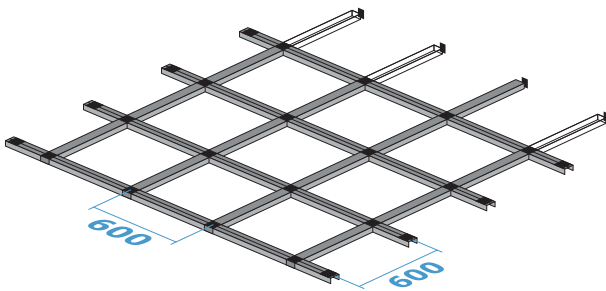

Promat® Modular Floor structure is acoustically dampened and decoupled with PROMADAMP® and Promasound to provide a maximum of acoustic comfort for shipowners and passengers.

The system allows a click-and-ready installation to accelerate the completion of the flooring and has been tested for its acoustic performance as per ISO 10140-2 AND ISO 717-1.

I. Underlying structure Promat® Modular Floor



Technical Data

Grid	600 x 600mm	500 x 500mm		
Generic description of components	Length	Length	Height	Weight
Long bar 	2400mm 	2000mm	30mm	2,1kg/m
Medium bar 	1200mm 	1000mm	30mm	2,1kg/m
Short bar 	540mm 	500mm	30mm	2,1kg/m
Adjustable Rubber Foot			35mm 55mm	0,21kg 0,26kg



Promat® MODULAR FLOOR

Installation

The Installation of Promat® Modular Floor must be done according the following steps. The long and medium bards come with (if not ordered otherwise) equipped with adjustable feet:

1. Lay the Promat® Modular Floor long bars and transversal Promat® Modular Floor short bars, to create a grid structure with 600x600 or 500x500 (mm) center.
2. Levelling of the structure.
3. Glueing the feed to the deck.
4. Lay of flooring panels, e.g. PROMARINE®-PX1.
5. Glue and screw the panels to the Promat® Modular Floor.

Always refer to Promat® Modular Floor installation instructions document where all the operations are detailed.

Workability

PROMARINE®-PX1 can be cut using normal woodworking tools or by using circular blades. It can be installed and adapted to specific tailor-made shapes to meet specific customer's requirements.

If a specific project has been developed by Promat technical office, cutting operations shouldn't be necessary on Promat® Modular Floor grid, nevertheless, steel specific cutting tools must be used.

During cutting operations use personal protective equipment (see below).

Handeling

Always use appropriate personal protective equipment (PPE) during cutting, working and installation activities independently from the chosen panel.

Refer to specific technical data sheet for further information. After use, thoroughly wash hands and any other parts that could have been in contact with the material.

Waste disposal

Refer to local legislation. If not available: The product is not classified as a dangerous substance and so no special provisions are required regarding the carriage and disposal of the product to landfill.

Storage

Store on a flat surface, in a dry area.

Acoustic properties

PROMARINE®-PX1

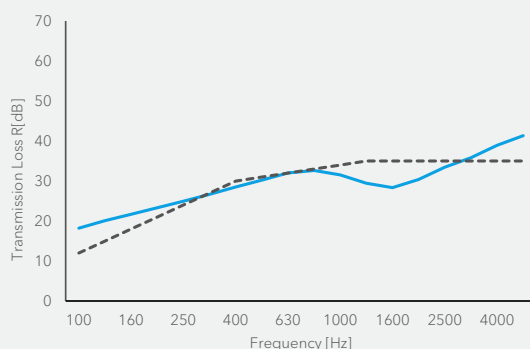

STEEL DECK + PROMADAMP CLSK2S + PROMAT® MODULAR FLOOR + PROMARINE®-PX1; $R_w = 53\text{DB}$

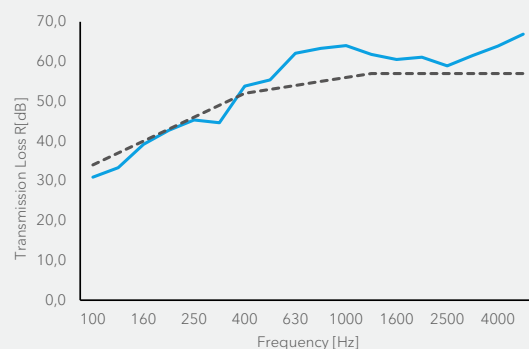

All specified technical data are mean values from the production which are subject to the usual fluctuations and do not represent guaranteed properties in the sense of a guarantee. All information corresponds to the current state of the art and has been presented and described to the best of our knowledge. Changes due to new findings are possible, errors and misprints are not excluded. With regard to any liability, our delivery and payment terms apply exclusively. Request safety datasheet. With the publication of this edition, all previously published datasheets are invalid.
© Copyright Etex NV, Brussels, Belgium. All rights reserved. 2021-09.

Etex Industry c/o Microtherm N.V., Industriepark-Noord 1, 9100 Sint-Niklaas, Belgium | T +32 (0)3 760 19 80 | F +32 (0)3 760 19 99
info@promat-industry.com www.promat-marine.com