

Promat



VENTILATION



COMPARTMENTATION

DURASTEEL[®]

**High performance fire
and blast protection**



**A maintenance-free
'fit and forget' system
providing quick,
adaptable, and simple
installation both
internally and externally**

INDEX

- 4 Introduction
- 6 Design Benefits
- 8 Testing

Key Sectors

- 10 Power Generation and Distribution
- 12 Transport
- 14 Commercial and Public Sector
- 16 High-Rise Offices and Buildings
- 18 Warehousing, Factories and Distribution

Case Studies

- 20 Manchester Airport
- 24 Stronelaigr Wind Farm

Applications

- 28 DURASTEEL® Stud Partitions
- 32 DURASTEEL® Composite Barrier System
- 34 DURASTEEL® Ceilings
- 38 DURASTEEL® Ducts
- 42 DURASTEEL® Doors

Note: Information correct at time of publication (see version number on back page). Please ensure you are using the latest version by visiting <https://www.promat.com/en-gb/construction/uk/durasteel/>

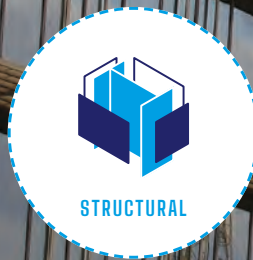

Cover image: Installed by dB Attenuation and Invicta in collaboration.
Project: Banbury Transformer Separation.



Promat is the global leader in passive fire protection

We offer you a complete portfolio of certified and tested products and systems to design and build a fully reliable fire safety solution for your building project.

With more than 60 years of experience and know-how, we are ready to help you protect people, buildings and assets.

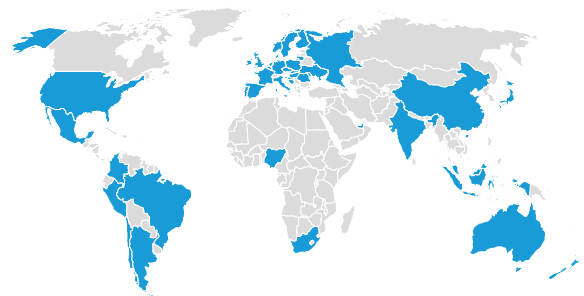

Promat operates in over 40 countries around the world.

OUR MISSION

We want to make the world safer, healthier and more sustainable for the generations of today and tomorrow.

Safety is a concept people need in order to grow, prosper and enjoy life, yet we take it for granted every day. This is why we offer the highest standard in fire safety for homes, offices, schools, hospitals, shopping malls and airports.

As the way we live, work and build constantly evolves, Promat wants to help maintain the highest level of fire protection. We offer you new products and innovations, so together, we can make this world a safer place.

Introduction

The effects of fire, blast and impact can be devastating, but with a properly designed and installed fire safety and protection system in place, the effects can be managed and minimised. Promat is driven by an uncompromising attitude to fire safety and specifiers can be confident of the performance of Promat DURASTEEL® due to an unparalleled range of testing on the product and applications.

DURASTEEL® is a fully certified and tested fire protection board. It is constructed as a composite panel of fibre-reinforced cement with punched steel sheets mechanically bonded to both outer surfaces. This delivers the strength and resistance required to withstand high impact and blast pressures, maintain structural integrity and provide up to four hours of fire protection.

It has been used successfully worldwide for many years and is the preferred choice for specifiers and project managers responsible for fire and blast applications due to its flexibility and modular nature.

DURASTEEL® is tested to British, European and other International standards (including ASTM), and can be used to create fire resistant walls, ceilings, ducts, cable enclosures and stand-alone fire and blast barriers. A range of DURASTEEL® doors is also available. Its unique features and benefits combine strength, impact, blast resistance and durability with exceptional fire resistance.



**FIRE RESISTANT**

Fully certified and tested fire protection board.

**DURABLE**

Composite panel of fibre-reinforced cement with punched steel sheets for strength and resistance.

**TESTED**

Tested to British, European and other International standards (including ASTM).

**BLAST RESISTANT**

Combines strength, impact, blast resistance, and durability with exceptional fire resistance.

**LIGHTWEIGHT**

Slim, lightweight, and space-saving profile, requiring no foundations and is suitable for retro-installation.

Design Benefits

SYSTEM PERFORMANCE

Key Benefits

- A maintenance free 'fit and forget' system providing quick, adaptable, and simple installation both internally and externally.
- Slim, lightweight, and space-saving profile, requiring no foundations and suitable for retro-installation.
- Fire performance remains unaffected from fire fighting operations and sprinkler activation.
- Fully demountable and has over 40 years of proven service life.
- Low sound transmission and good acoustic insulation performance.
- Tested for mechanical and seismic vibration.
- Fully traceable and manufactured by Etex in the UK under ISO 9001, ISO 14001 and ISO 45001 health and safety management systems.
- Tested with a range of service penetrations and fire doors.
- CERTIFIRE approved CF 418 (Doors) / CF 429 (Partitions and Ceilings) / CF 480 (Ductwork) / CF 607 (Composite Barriers).
- Licensed installer network with manufacturer's Certificate of Conformity available for installations.

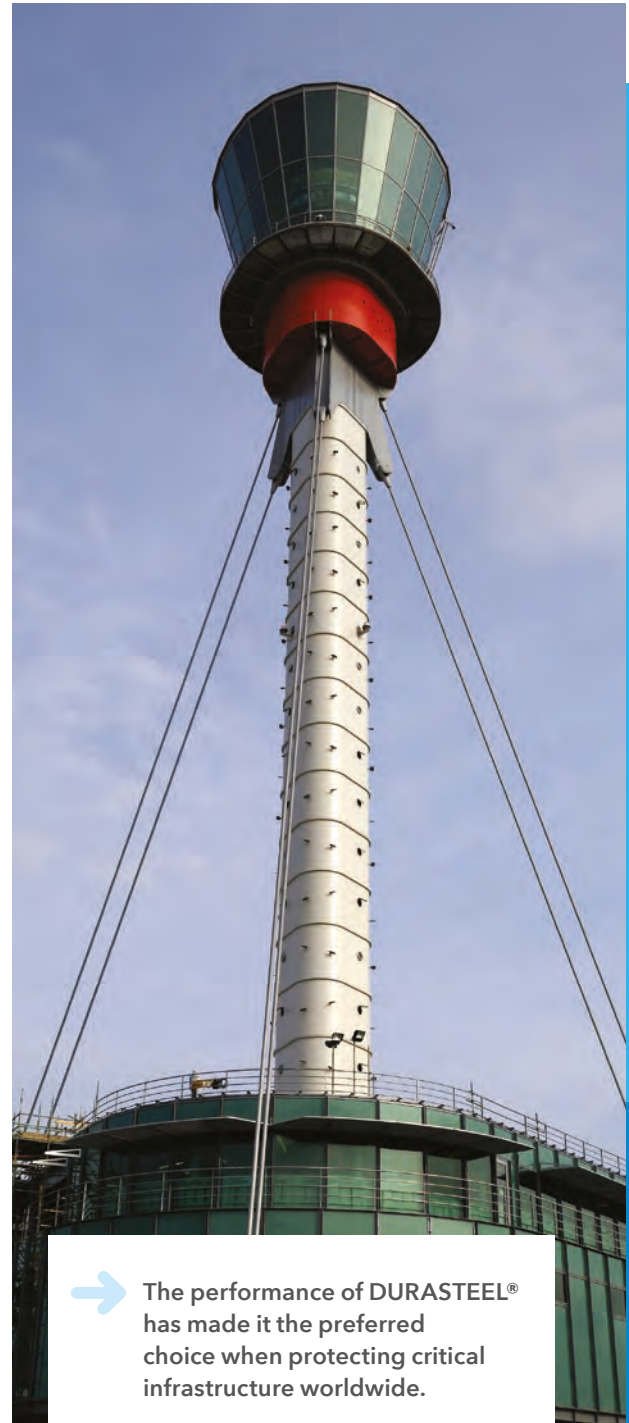

→ The performance of DURASTEEL® has made it the preferred choice when protecting critical infrastructure worldwide.

**SYSTEM PERFORMANCE**

Able to withstand high impact and blast pressures and maintain structural integrity, offering advantages over blockwork walls which can fail under high impact due to failure of mortar joints.

**A VERSATILE PRODUCT**

For use in storage vaults, electrical plants, fuel storage and boiler rooms to create walls, ceilings, escalator pits and to protect building services.

**RISING TO THE OCCASION**

DURASTEEL® is ideal for the protection of high-rise offices and hotels from the many fire and blast threats present.

**ENVIRONMENT PROTECTION**

DURASTEEL® provides safety and protection for people and buildings where the risk of fire can have a significant environmental impact.

Testing

PROPERTIES AND PERFORMANCE

Material class	Classed as 'non-combustible' to BS 476: Part 4: 1970 and A1 to BS EN 13501-1
Surface spread of flame	BS 476: Part 7: 1987
Building Regulation classification	A1 to BS EN 13501-1
Alkalinity (approximately) pH (core)	10 - 13
Coefficient of expansion (20-100°C)	15 x 10 ⁻⁶ mm (9.5mm)
Nominal moisture content (air dried)	6%
Thickness tolerance of standard boards	+1.0mm to - 1.0mm (9.5mm) +1.5mm to - 0.0mm (6mm)
Length x Width tolerance of standard	±2.0mm (6mm and 9.5mm)
Fire resistance	Can provide up to 4 hours of fire resistance. Classified from EI30 to EI240 according to BS EN 13501-2
Blast resistance	Tested from 0.3 to 2 bar over pressure and impact resistant to 4000J after 3 hour fire test in accordance with DIN 4102 Parts 2 and 3 requirements
Hydrocarbon fire resistance	Lloyds Approved H0 to H120 capable of maintaining fire resistance post-blast
Hose stream resistance	Tested to a 45 Psi (310 kPa) pressure hose (ASTM E119)
Acoustic characteristics	Sound reduction index of 33 R _w dB
Thermal Conductance (at 9.5mm)	60 W/mK at 20°C

MECHANICAL PROPERTIES

Flexural strength, MoR	6mm	Average, dry	109 N/mm ²
Flexural strength, MoR	9.5mm	Average, dry	84 N/mm ²
Modulus of elasticity E	6mm	Average, dry	55000 N/mm ²
Modulus of elasticity E	9.5mm	Average, dry	40000 N/mm ²

BOARD DIMENSIONS

Thickness (mm)	Length x width (mm)	Approximate weight (kg/m ²)	
		Dry	With approx 6% moisture
6	2500 x 1200	15.9	16.8
9.5	2500 x 1200	19.8	21.0
9.5	2000 x 1200	19.8	21.0



SUMMARY FIRE TEST INFORMATION*

Type of construction	Description	Test Standard	Maximum Performance		
			Stability (ducts)	Integrity	Insulation
Barriers/Partitions	DURASTEEL® only	BS 476 EN 13501	- -	240 240	30 30
	DURASTEEL® and stone wool insulation	BS 476 EN 13501	- -	240 240	240 240
	DURASTEEL® and PROMATECT®-250	BS 476 EN 13501	- -	240 240	240 240
Ceilings	DURASTEEL® only	BS 476	-	240	120
	DURASTEEL® and stone wool insulation	BS 476	-	240	240
	DURASTEEL® and PROMATECT®-250	BS 476	-	240	60
Ducts	DURASTEEL® only	BS 476	240	240	30
	DURASTEEL® and stone wool insulation	BS 476	240	240	240
Service enclosures	DURASTEEL® only	BS 476	-	240	-
DURASTEEL® Doors	DURASTEEL®	BS 476	-	240	-

* The above table is a summary of DURASTEEL® fire testing and there is other testing on bespoke requirements available. Contact technical support for further information

Key Sectors

POWER GENERATION AND DISTRIBUTION

Due to the processes that take place, and the variety of combustible materials on-site, power stations are considered to be of high risk. Even a fire or blast within one area of a power station can significantly reduce or cease operation of the entire station for weeks, and the potential risk to life and damage to property, services and the environment requires implementing the highest level of fire and blast protection. DURASTEEL® is a proven system solution in worldwide power facilities.

DURASTEEL® provides fire and blast solutions to the energy, power generation and distribution sectors including power stations and electrical sub-stations. It has been used in many high profile projects in the nuclear, oil and gas and renewable sectors. DURASTEEL® systems protect personnel, facilities, structures and equipment from the effects of blast, impact, explosion, fire and smoke in hazardous environments.

It will also help stop the spread of a fire and contain an explosion within its original source area, minimising damage, risk to life, disruption, and provide protection to surrounding areas. Transformers are a vital part of electrical distribution but carry a risk of explosive fire without warning. Multiple adjacent transformers are often found on-site and this can lead to a total loss of power distribution if a fire and blast in one creates a 'domino effect'.

DURASTEEL® barriers installed between transformers prevent catastrophic damage by isolating the blast and the effects of the explosion, minimising subsequent disruption. Commercial, industrial buildings and large residential developments often have substations with power distribution transformers installed either within the building or in close proximity.

Many are critical energy networks, used, for example, to maintain supply to banking, government, transport, defence, hospitals or businesses where the implications of a total power failure can be significant.



Image: Courtesy of SBL Fire Solutions



FIRE PERFORMANCE REMAINS UNAFFECTED FROM FIRE FIGHTING OPERATIONS AND SPRINKLER ACTIVATION.

Key Sectors

TRANSPORT

DURASTEEL® has a key role to play in the safety of transportation terminals, systems and infrastructure throughout the world.

AIRPORTS

With millions of passengers each year, as well as luggage and cargo, airport operators are duty bound to provide the highest standard of safety to staff, passengers and contractors. DURASTEEL® is used in critical areas of an airport to help protect people and their belongings, buildings, and information systems. It is typically used as a fire barrier in areas of non-public access in terminal buildings, and linings to services tunnels and corridors. Additionally, it is employed as fire, impact, and blast protection in passenger terminal areas, escape routes, luggage storage, escalator pits, internal transport systems (such as connecting railways), workshops, shafts, ducts, plant rooms and transformer enclosures. It has been successfully specified and installed in many worldwide airport projects, reducing insurance costs and providing high levels of safety.

RAIL AND METRO

DURASTEEL® is lightweight and robust, making it ideal for the external environment of all trackside, station, and rolling stock fire protection requirements. It is also widely used in rail tunnels, inside stations and terminal buildings. As a proven system solution, already installed in rail and metro facilities throughout the world including the London Underground it provides protection to ensure the safety of passengers and staff, while reducing the impact of loss of service in the event of a fire or explosion.

DURASTEEL® is also used for the protection of services and for smoke extract or ventilation duct systems. Promat DURADUCT® SMT and LT ductwork systems can be made to bespoke requirements and are commonly used in London Underground projects.

ROAD TUNNELS

DURASTEEL® is widely used in road tunnels, where there is risk of a major fire due to the presence of significant levels of highly combustible materials in an enclosed area. It is also installed in public areas located in close proximity to explosion and fire risks.



**IDEAL FOR ROAD TUNNELS**

Providing protection in road tunnels throughout the world.

**LONDON UNDERGROUND INSTALLATIONS**

It is a proven solution for the safety of passengers and staff in the London Underground network and reduces the impact of loss of service.

**AN ADAPTABLE SYSTEM**

Suitable for use in walls, doors, ceilings, stairwells, escalator pits, ducting and cable protection – all common in transport projects.



Key Sectors

COMMERCIAL AND PUBLIC SECTOR

Effective fire, blast and impact protection is particularly important in commercial and public sector buildings, due to the high volume of people present, the value and importance of documents, data, or items kept within, potential terrorist threats, and the possible disruption and impact to businesses or the economy if certain information, or items, are destroyed, or a facility is not in operation.

DURASTEEL® systems provide the following benefits to those specifying products for fire, blast, and impact protection for structures in the commercial and public sectors:

- Protection and safe evacuation of employees, officials and the public.
- Protection of buildings, IT systems, media or electronic data, documents, and valuable or important items.
- Protection to ensure there is minimal disruption to business and the public.
- Protection of surrounding areas and the environment.

DURASTEEL® is the first choice for both new and upgrade projects where fire, blast, and impact protection is critical and in a wide range of structures for the commercial sector including:

- Hotels
- Retail Parks and Leisure Complexes
- Public Buildings
- Data Centres
- Government Institutions



**PRESERVING DATA AND RECORDS**

Ideal for the protection of digital data, vital documents, media and artifacts from fire, heat, impact, moisture or vibration.

**MAINTAINING CRITICAL SERVICES**

A fire or explosion can cause loss or threat to key services; it is important for these to be maintained for the banking, government, health, and business sectors.

**PROTECTING THE PUBLIC**

Provides vital protection to the public in large building projects, such as retail parks and leisure complexes.

**HELPING THE EMERGENCY SERVICES**

Minimises disruption and damage to facilities and gives the fire services vital planning time to preserve life and property.

Key Sectors

HIGH-RISE OFFICES AND BUILDINGS

A high-rise building requires stringent protection from fire, blast and impact due to the number of people working or living within.

Due to the nature of a high-rise structure ensuring escape routes are maintained for the safe evacuation of those present is crucial. DURASTEEL® is the perfect solution because of its application versatility and modular nature, meeting even the most complicated bespoke designs or safety needs.

DURASTEEL® is suitable for escape routes and fire doors, in fuel storage and boiler room enclosures, ceilings above lift shafts and lift door panels, escalator pits, ceilings to fan rooms, smoke extract and pressurisation ducts, storage areas, curtain wall fire breaks, penetration seals, plant rooms and transformer enclosures.

Systems are designed to ensure the integrity of fire compartments when services are required to continue functioning in the event of fire, as well as protecting life, and reducing damage to buildings and minimising subsequent disruption.



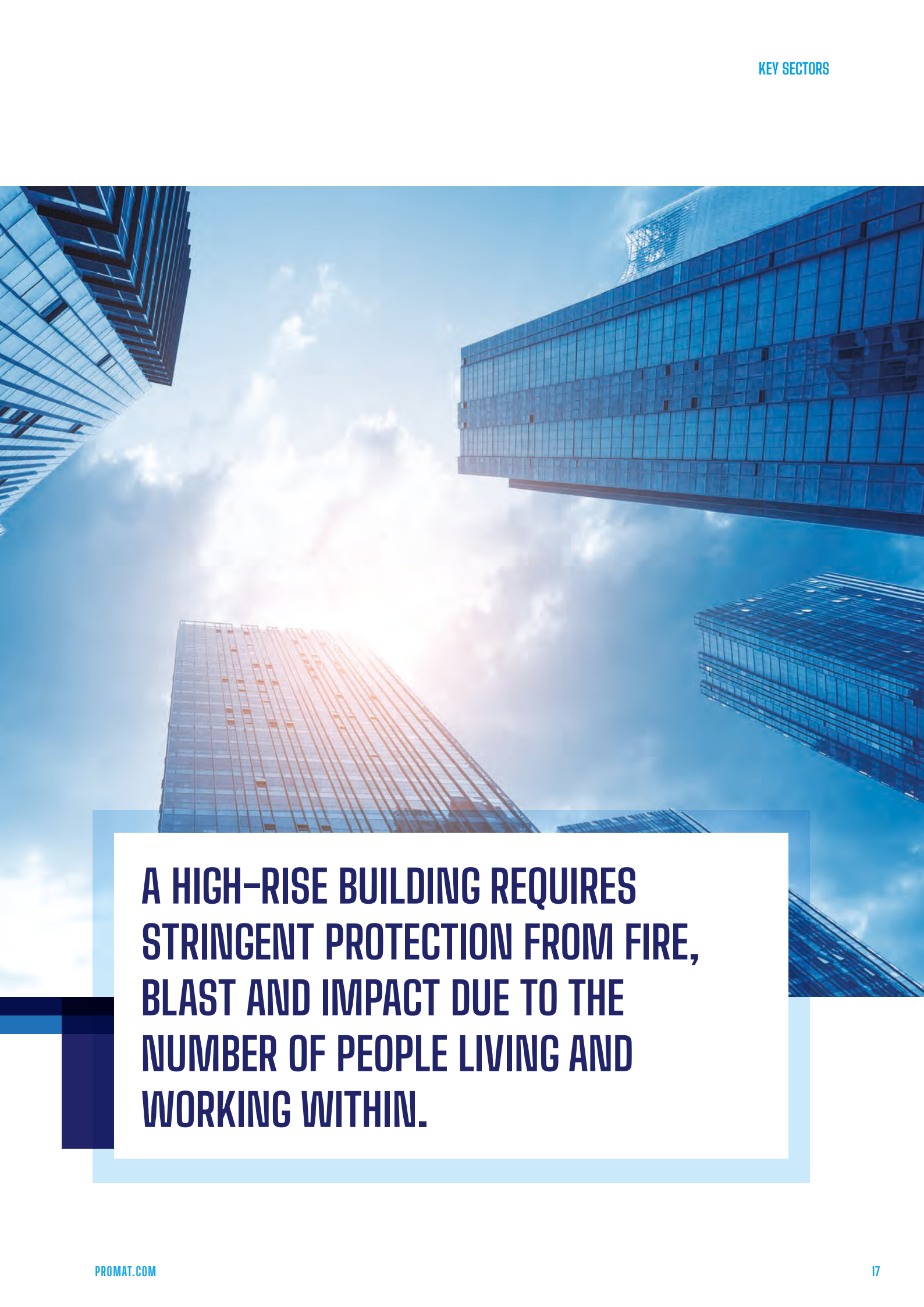

**A HIGH-RISE BUILDING REQUIRES
STRINGENT PROTECTION FROM FIRE,
BLAST AND IMPACT DUE TO THE
NUMBER OF PEOPLE LIVING AND
WORKING WITHIN.**

Key Sectors

WAREHOUSING, FACTORIES AND DISTRIBUTION

A warehouse or factory is considered a high-risk environment as they usually house a variety of combustible or valuable products and equipment. All these factors increase the potential of a fire starting and spreading quickly. DURASTEEL® will contain fire within compartments of a production area or storage facility, thus allowing for the safe evacuation of personnel, minimising disruption of processes and preventing the destruction of valuable stocks or equipment.

DURASTEEL® fire barriers are a highly effective solution for protection from the devastating effects of fire in factories, warehouses and distribution facilities. Those responsible for fire safety in warehouses and factories use DURASTEEL® due to its performance, ensuring the protection of life and inventory in the event of a fire.

DURASTEEL® products can withstand rapid increases in temperature caused by the heavy fire loading typically found in warehouses, and can also stop heat transferring throughout the facility resulting in further damage. It allows for effective escape routes to be created and acts as a life support system for the building until the fire service arrive.

By using DURASTEEL® damage is minimised - saving stock, rebuild costs, lives and giving businesses the ability to continue to service their customers' needs.



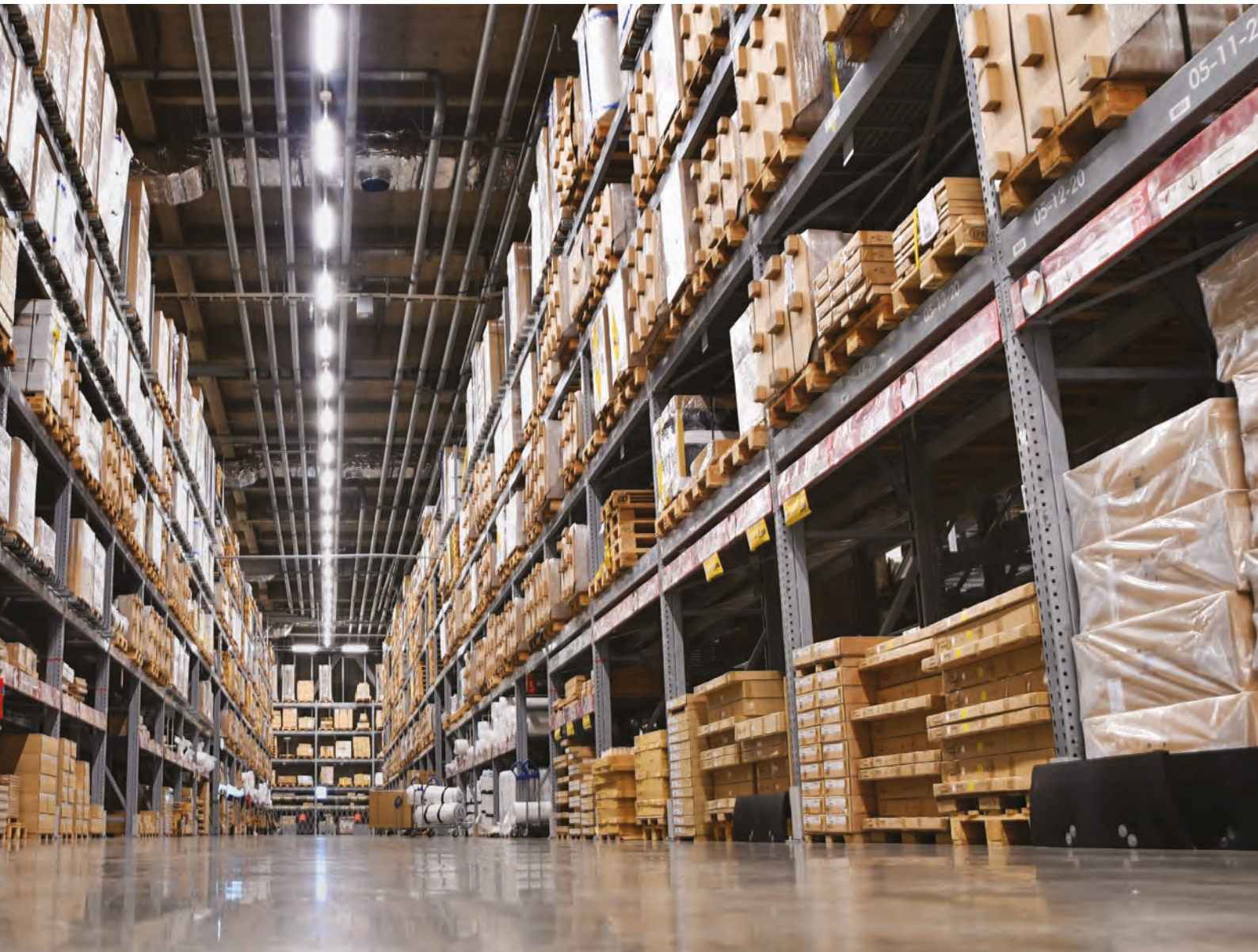

THE HEAVY FIRE LOADING TYPICALLY FOUND IN WAREHOUSES OR DISTRIBUTION CENTRES INCREASES THE POTENTIAL OF A FIRE STARTING, AND SPREADING QUICKLY.

APRIL 2021

Case Study

MANCHESTER AIRPORT

DURASTEEL® delivers safety and support for airport expansion project.

PROJECT OVERVIEW

Promat has played a key role in the £1bn Manchester Airport Transformation Programme (MAN-TP), which will see the airport significantly grow and modernise throughout the early 2020s in order to become a world-class transport hub.

This investment will involve the creation of an entirely new Terminal 1, doubling the size of Terminal 2 and include major upgrades to Terminal 3. To accommodate this growth, eight new transformer units were added to improve the airport's electrical supply.

To ensure these transformer units were properly protected, DURASTEEL® boards were used to create ceilings around them that would provide both fire and blast protection while simultaneously solving a number of intricate building design challenges.

DESIGN AND SPECIFICATION

The buildings that house the transformers need to minimise the impact of any potential fires or explosions as much as possible. This is especially crucial within an airport as, while not connected to the terminals, should the fire spread it could knock out the electricity or significantly affect operations for a critical piece of national transport infrastructure.

An additional design complexity was that the ceiling would have to self-span across a large distance while still having the strength to accommodate maintenance loads from above, have services hung from below and include movement joints at the interface between the boards and the walls.

To solve this, Promat advised the architects at an early stage of the project to use DURASTEEL® boards to create a bespoke, 60-minute fire-rated ceiling that would be strong enough to cope with the structural challenges. The flexibility of the DURASTEEL® system means it flexes to absorb the energy from a blast, instead of breaking.

KEY POINTS

- Sector: Airports
- Product: DURASTEEL®
- Client: Manchester Airport
- Architect: Pascall+Watson
- Contractor: Laing O'Rourke
- Subcontractor: The Invicta Group
- Project duration: Nov 2018 - Feb 2019





INSTALLATION

The project's subcontractor The Invicta Group coordinated a final design with the third party structural and fire engineers, which involved over 300m² of DURASTEEL® being used for the transformer room ceilings.

Normally, drop rods would be fixed from the concrete above which would make it easier to install fire-resistant boards. However, for this project the ceiling would also have to act as a floor so the boards were attached to the ceiling's surrounding steel frame. Thanks to the strength of the boards, they could be installed in this manner and still be able to support the weight of maintenance crews walking on top of them as well as building services such as ducts, cables and lights that would be suspended below.

On completion, Promat attended the project to confirm that the installation was in line with its guidelines and that it met the third-party certification requirements and structural engineer's design.

FINAL RESULTS

Manchester Airport's new transformer buildings presented a unique challenge, as it's not often that this blend of structural and fire safety properties is required at one time. Being able to meet all these criteria demonstrates the flexibility and versatility of the DURASTEEL® boards, as it's unlikely that an alternative material would have been able to play the same role.



“ Overall, this was a successful installation closely coordinated with the project team, and was completed well within the required timeframe for energisation of certain areas/rooms.

The expertise and experience that both Promat and Invicta have in working on demanding projects meant that they could provide the design and installation support required for Manchester Airport to specify a high-performance ceiling, safe in the knowledge that it would meet the demands of the Manchester Airport Transformation Programme.

**BENN LARKIN, SALES MANAGER
INVICTA FIRE PROTECTION**



JUNE 2021

Case Study

STRONELAIRG WIND FARM

Promat systems enhance fire safety at one of SSE's windiest renewable energy sites.

PROJECT OVERVIEW

As a leading provider of renewable energy across the UK, SSE Energy Services aims to drive the transition to a net zero carbon world through the development, construction and operation of state-of-the-art renewable energy assets. To support this mission, in 2017 SSE built a wind farm in Stronelairg - a remote area of Scotland near Loch Ness. At an elevation of around 600 meters above sea level, it is one of SSE's windiest sites. The site includes 66 wind turbines and has the capacity to generate 228 MW of energy.

As part of the project, SSE needed to create three transformer enclosure bays on the site, each of which had to meet a demanding four-hour fire-rated standard. This required the installation of walls and ceilings - as well as internal access doors for maintenance personnel - that would all meet this high-level of fire resistance. It was also necessary that various penetrations, including wall bushings, were able to safely pass through the barriers in the enclosure bays.

An additional challenge was that the project would have to be completed in an isolated setting where the work would be constantly exposed to cold, wet weather conditions. Having worked with Promat and its products for more than a decade, the project's subcontractor, Invicta, knew its fire protection solutions would be a perfect fit for the wind farm's unique requirements.

DESIGN AND SPECIFICATION

Invicta and independent structural engineers designed a bespoke 1800m² wall and ceiling system consisting of DURASTEEL® and VERMICULUX® boards.

DURASTEEL® is a high impact, blast and fire-resistant system that provides up to 240 minutes integrity rating from fire attack from either side, meaning that a fully developed fire would not be able to pass through one side of the wall to the other for a period of four hours. The bespoke solution designed and constructed by Invicta was based on standard single skin, integrity only DURASTEEL® wall and ceiling systems, tested and certified by Promat.

KEY POINTS

- Sector: Renewable energy
- Products: DURASTEEL®, VERMICULUX®
- Client: SSE Energy Services
- Architect: Jones Lang LaSalle
- Contractor: BAM Nuttall
- Subcontractor: The Invicta Group
- Project duration: Nine weeks



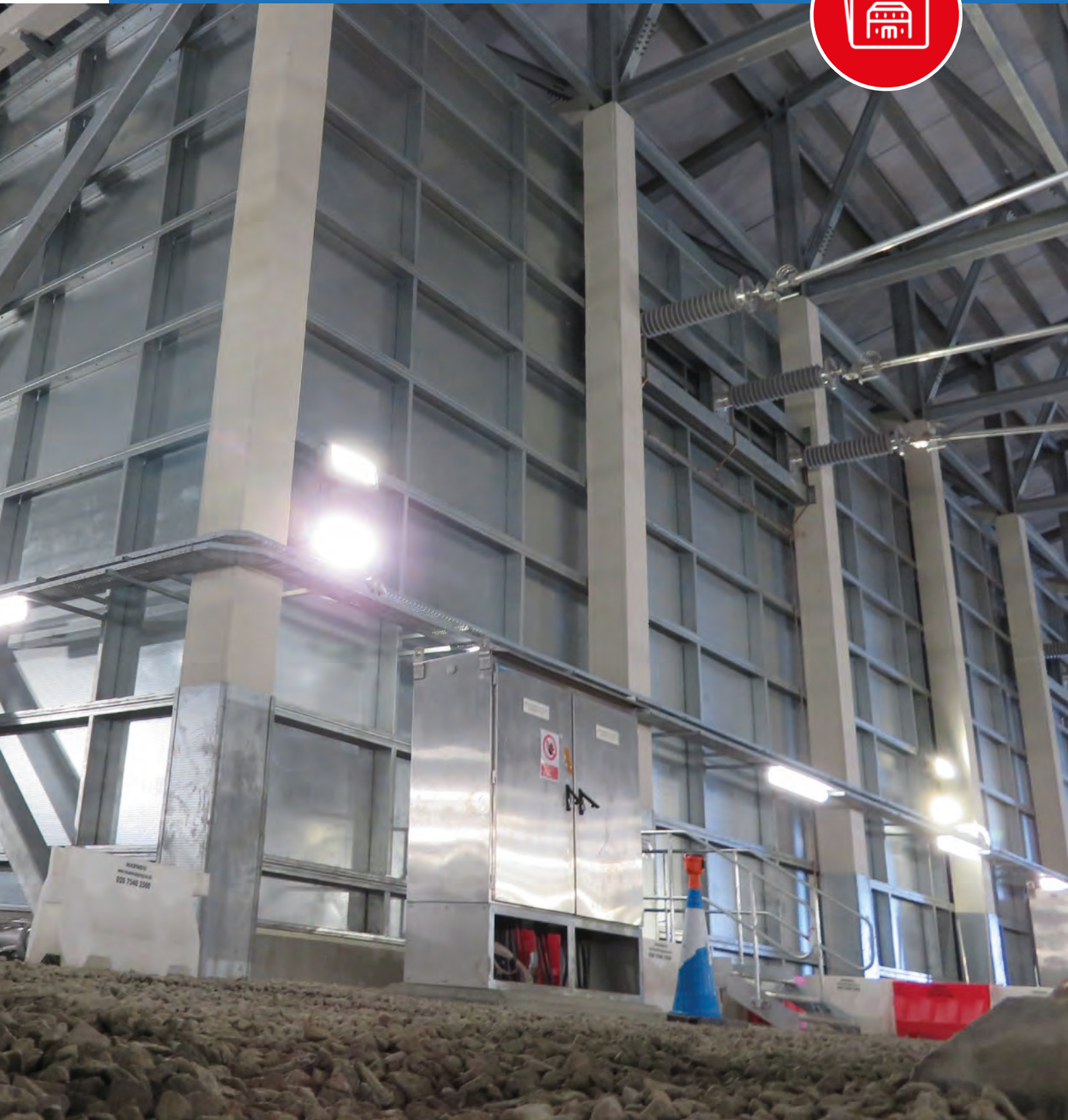

At the Stronelairg site, the DURASTEEL® system was accommodated within the transformer enclosure bays' structural steel construct in order to give it stability in the event of a fire. The solution means that even if there is a fire, the power station can keep running as the other transformers won't be affected, which is crucial when it comes to such an important piece of national energy infrastructure.

INSTALLATION

The main installation challenge with this project was that it was based at an altitude of more than 600m, meaning that site delivery and access points were extremely difficult to get to. The site's isolated location meant that getting to the project's access point required driving ten miles up a man made service road, travelling a further five miles to base camp and then an additional five miles to the working platform. The altitude and geography also meant that any solution would have to be constructed and able to fully function whilst facing extreme climate conditions such as temperatures of -10°C, high winds and heavy snow. It was necessary to be able to carry on with construction in these extreme conditions to complete on schedule.

DURASTEEL® lent itself well to both of these challenges because as a board product it can be easily transported and installed onsite, plus its modular application nature ensures speedy application. Specialist all-terrain access equipment was required to overcome the challenging site conditions and safely construct the system. The walls themselves had to be erected without the main roof being in position and during both high winds and heavy snow. Thankfully, because the products used could be easily constructed in small, lightweight components with no lifting equipment required, they were suitable for installation even in such difficult working conditions.

In addition, as the DURASTEEL® product is screwed and bolted together there is no requirement for cement/ mortar, meaning that the cold weather was not an issue. The programmed time for installation was 12 weeks, with seven Invicta DURASTEEL® installation engineers on-site at any one time.





“ The Durasteel solution was ideal for this project, as it offered complete compartmentation acting as fire enclosures, protecting each transformer from the adjacent transformer and was designed to offer cable support where required. Service openings were formed for passing wall bushings to distribute power throughout the building. As well as protecting the transformers, this solution also protects the rest of the building facility.

BENN LARKIN, SALES MANAGER
INVICTA FIRE PROTECTION

FINAL RESULTS

Despite working in extremely harsh conditions, which required a blend of different requirements, the unique project was completed by Invicta within nine weeks – three weeks ahead of schedule. Upon completion of the project, Invicta presented a full handover to SSE, which included third-party certification of the DURASTEEL® barriers, ceilings, doors and fire seals, confirming that the project was completed to the required standards. As part of this, one of Promat’s technical support technicians attended the site to inspect and provide a Certificate of Conformity for the installation.

Using Promat’s solutions, the site’s fire safety was enhanced significantly, which not only provided peace of mind to the client, but also ensured the power station would be able to keep running in the event of a fire in one of the transformers. Not many wall and ceiling systems are able to provide a four-hour fire rating, which is a demanding requirement, typically only found in high-risk industrial settings such as the power industry. The project also showcased how effectively Promat’s specialist solutions and products could slot into large, unique and complex installations.

Applications

DURASTEEL® Stud Partitions

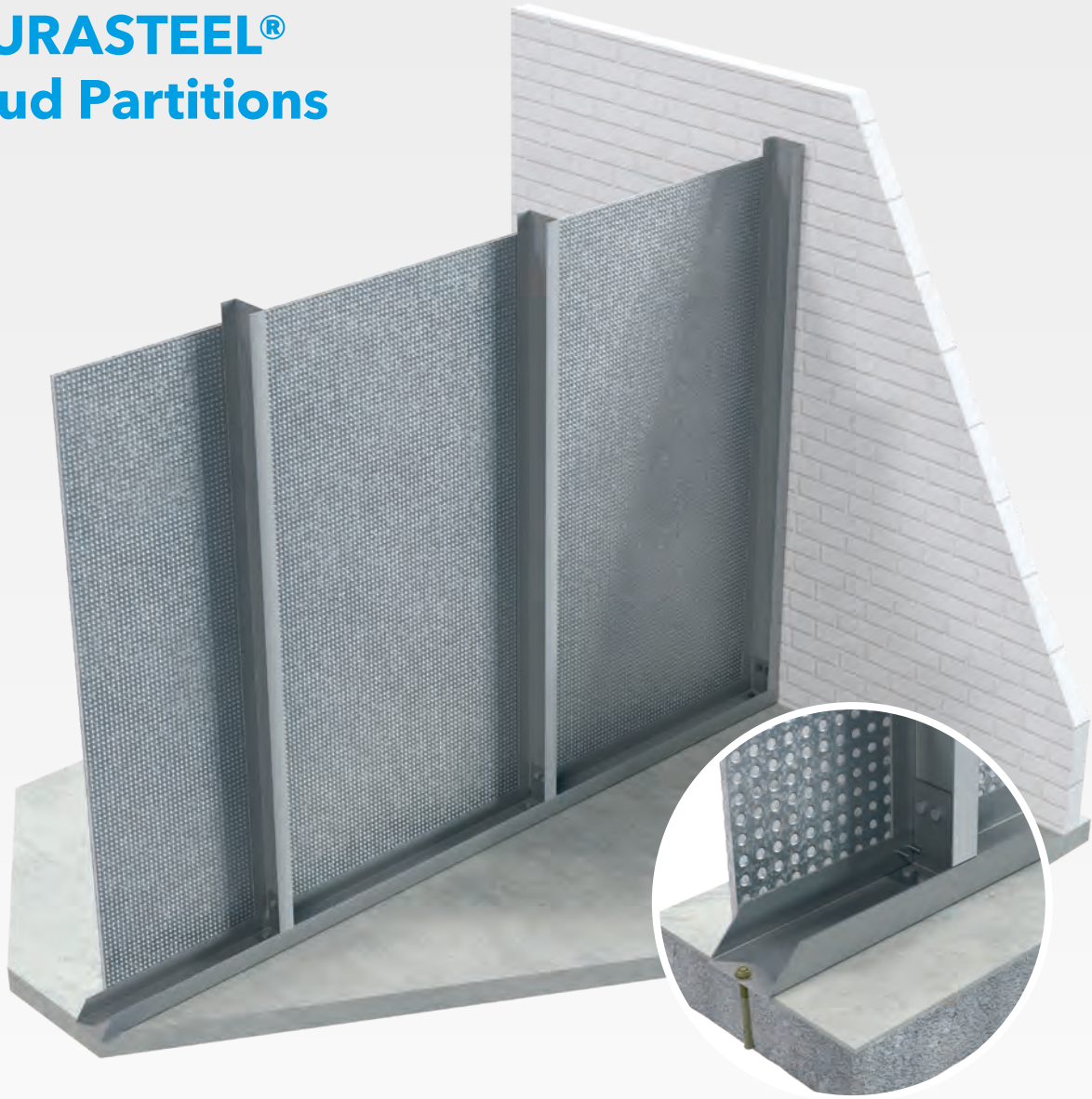

DURASTEEL® PARTITIONS PROVIDE FIRE PROTECTION FOR UP TO 240 MINUTES AND CAN BE BUILT AS INSULATED AND UNINSULATED BARRIERS, TESTED TO BOTH EUROPEAN AND BRITISH STANDARDS.

**DURASTEEL® Fire Barrier E 240 Integrity only
(Fire attack from either face)**

Fire resistance	240 minutes integrity only
Channel (minimum)	80mm x 60mm x 3mm (for heights up to 6m)
Overall width	89.5mm
Weight (nominal)	27kg/m ²
Estimated sound reduction	33 dB

Note: All drawings are for illustrative purpose only.

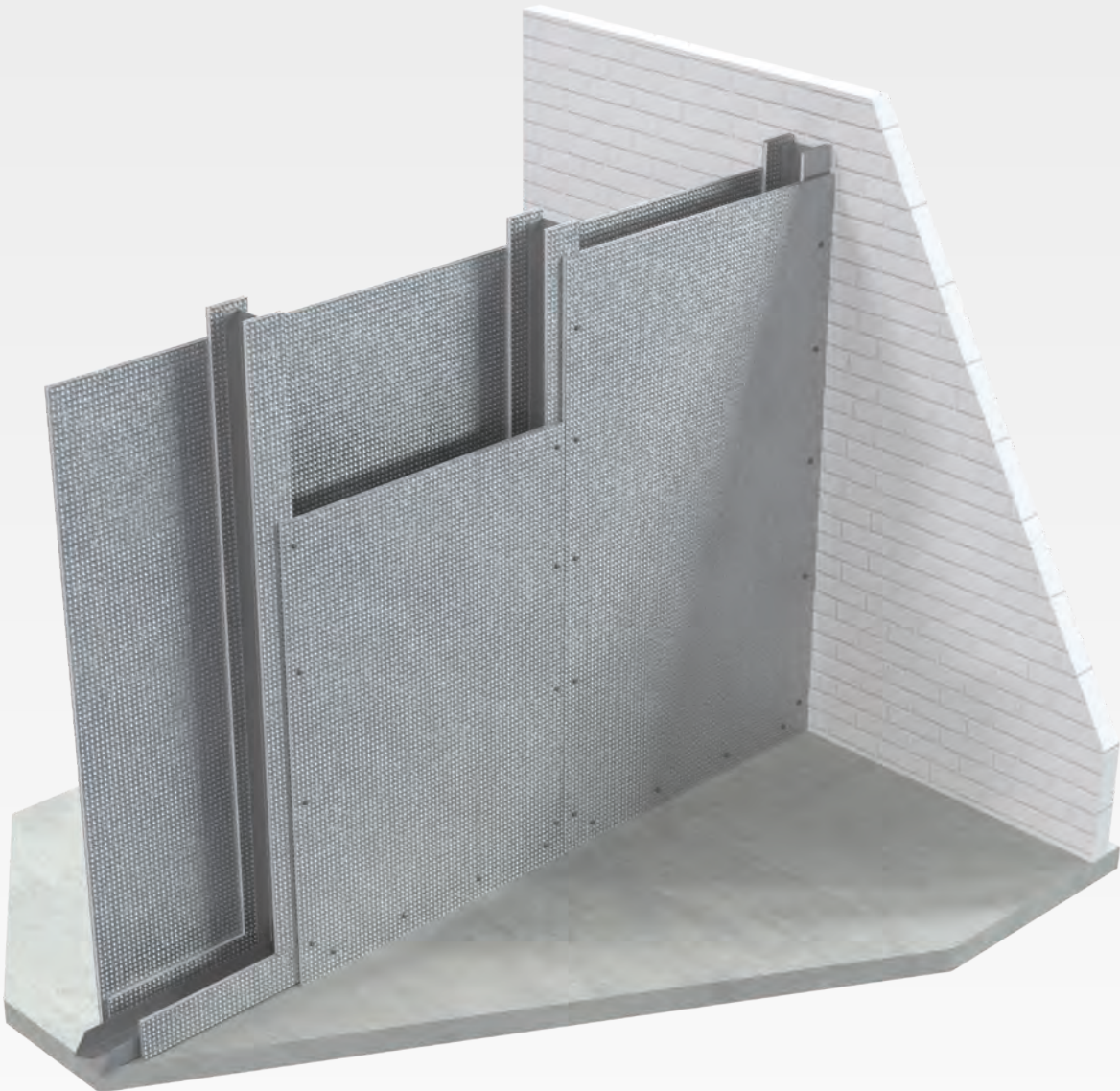

DURASTEEL® Fire Barrier E 240 - EI 60 (Fire from either face)	
Fire resistance	240 minutes integrity 60 minutes insulation
Channel (minimum)	80mm x 60mm x 3mm (for heights up to 6m)
Overall width	118mm
Weight (nominal)	51kg/m ²
Estimated sound reduction	42 dB

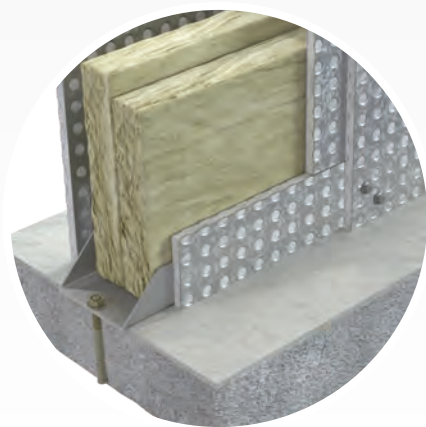
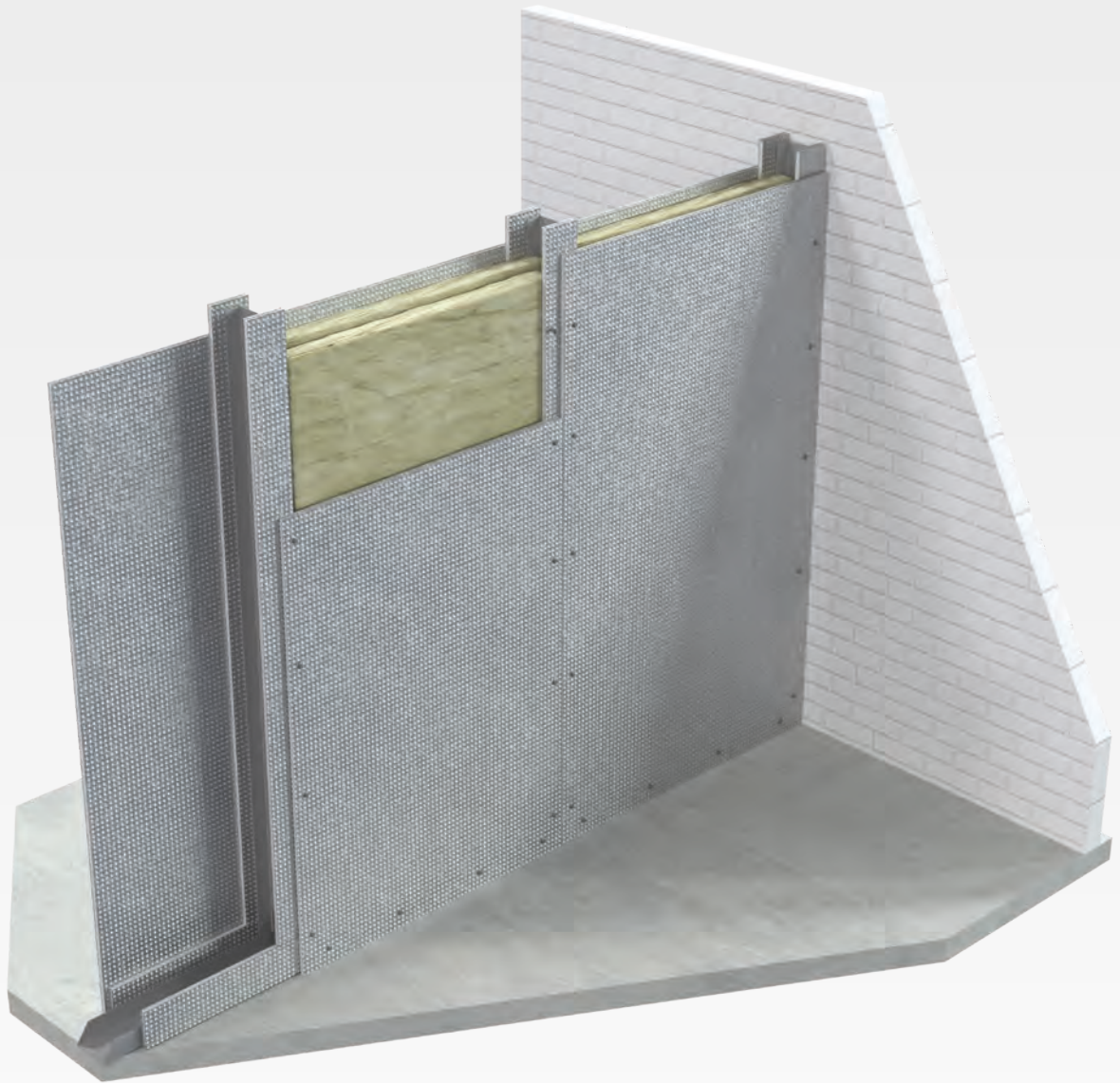

DURASTEEL® Fire Barrier E 240 - EI 120
(Fire attack from either face)

Fire resistance	240 minutes integrity 120 minutes insulation
Channel (minimum)	80 mm x 60 mm x 3mm (for heights up to 6m)
Overall width	118mm
Weight (nominal)	51kg/m ²
Estimated sound reduction	47 dB

Note: All drawings are for illustrative purpose only.

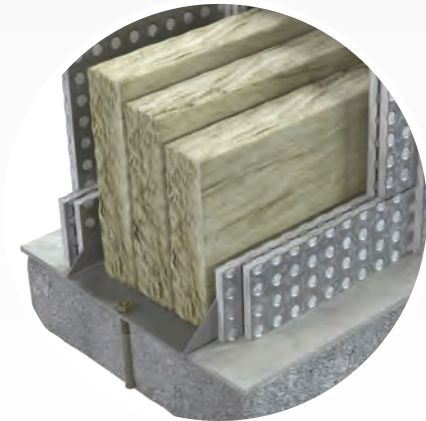
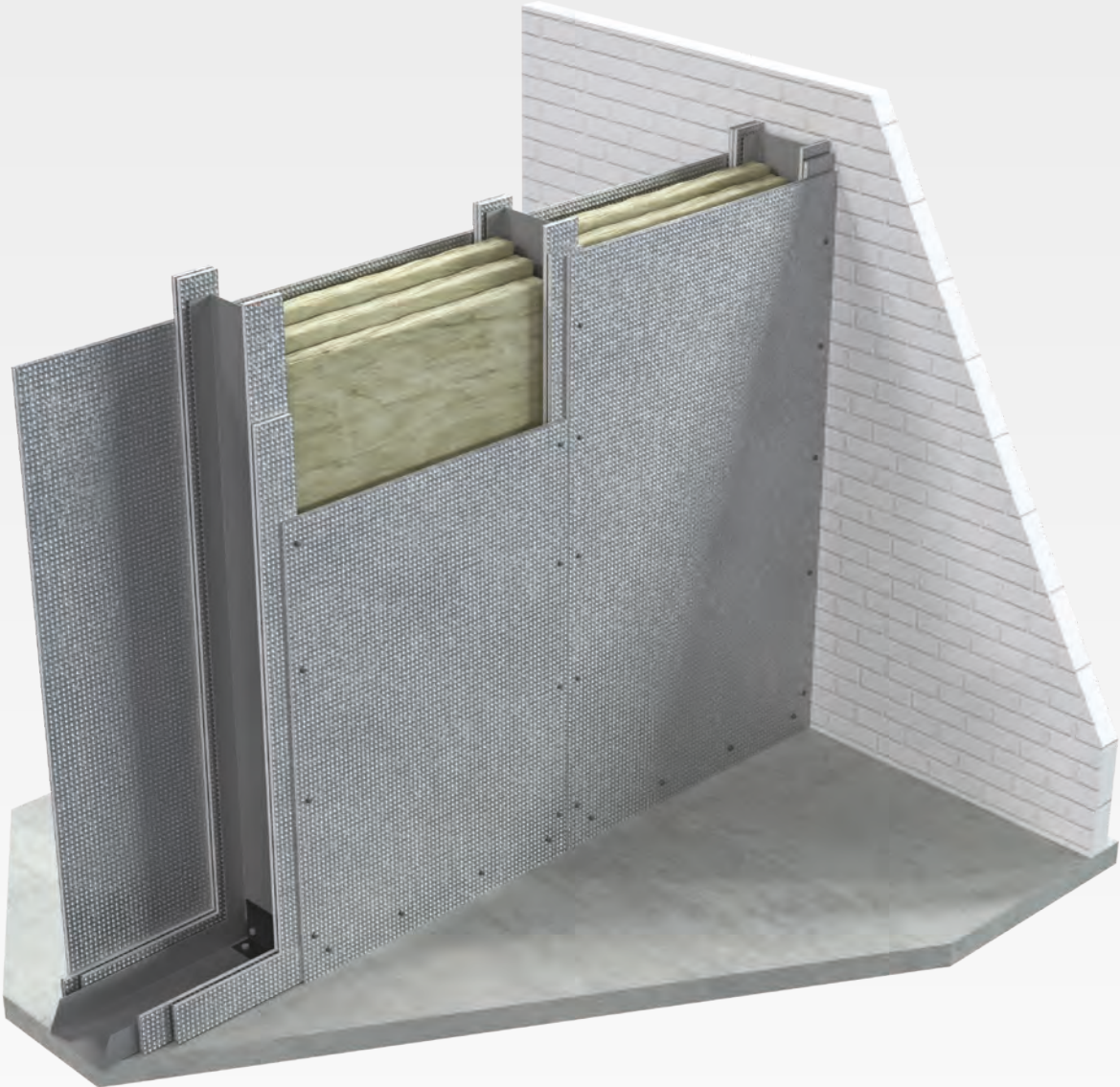

DURASTEEL® Fire Barrier EI 240 (Fire attack from either face)	
Fire resistance	240 minutes integrity 240 minutes insulation
Channel (minimum)	150mm x 60mm x 3mm (for heights up to 6m)
Overall width	207mm
Weight (nominal)	72kg/m ²
Estimated sound reduction	50 dB

DURASTEEL® Composite Barrier System

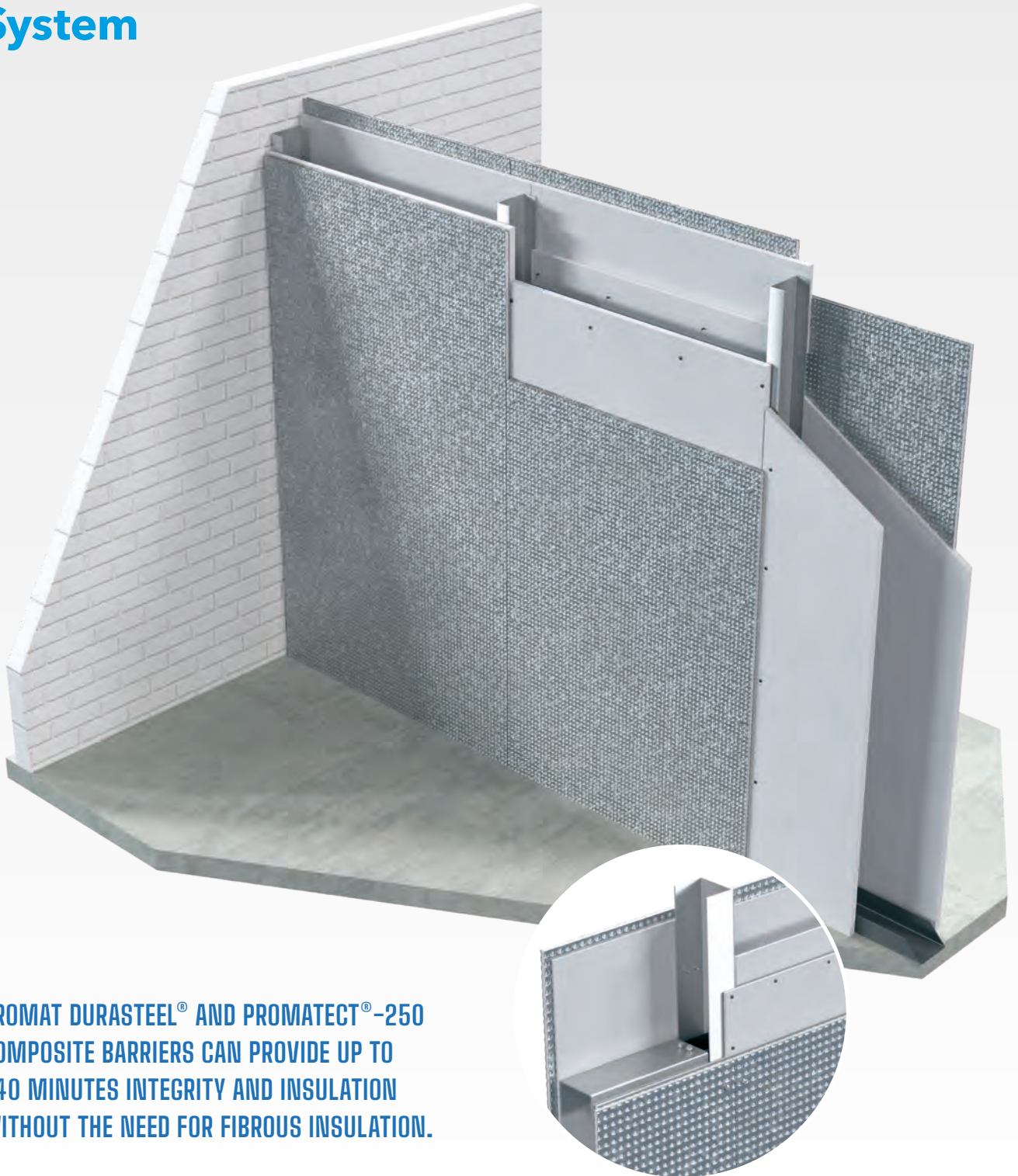

**PROMAT DURASTEEL® AND PROMATECT®-250
COMPOSITE BARRIERS CAN PROVIDE UP TO
240 MINUTES INTEGRITY AND INSULATION
WITHOUT THE NEED FOR FIBROUS INSULATION.**

Note: All drawings are for illustrative purpose only.

60 MINUTE**DURASTEEL® Composite Barrier System (E 240 - E 160)**

Size of channel stud required	Acoustic sound insulation R_w (assessed)
80mm x 60mm x 3mm (for heights up to 5.35m)	42 dB
150mm x 60mm x 3mm (for heights up to 8.5m)	45 dB

120 MINUTE**DURASTEEL® Composite Barrier System (E 240 - EI 120)**

Size of channel stud required	Acoustic sound insulation R_w (assessed)
80mm x 60mm x 3mm (for heights up to 4.4m)	43 dB
150mm x 60mm x 3mm (for heights up to 7.15m)	45 dB
250mm x 60mm x 3mm (for heights up to 9.8m)	47 dB

180 MINUTE**DURASTEEL® Composite Barrier System (E 240 - EI 180)**

Size of channel stud required	Acoustic sound insulation R_w (assessed)
80mm x 60mm x 3mm (for heights up to 4m)	44 dB
150mm x 60mm x 3mm (for heights up to 6.3m)	45 dB
250mm x 60mm x 3mm (for heights up to 8.75m)	47 dB

240 MINUTE**DURASTEEL® Composite Barrier System (EI 240)**

Size of channel stud required	Acoustic sound insulation R_w (assessed)
80mm x 60mm x 3mm (for heights up to 4m)	44 dB
150mm x 60mm x 3mm (for heights up to 5.7m)	45 dB
250mm x 60mm x 3mm (for heights up to 8m)	47 dB

DURASTEEL® Ceilings

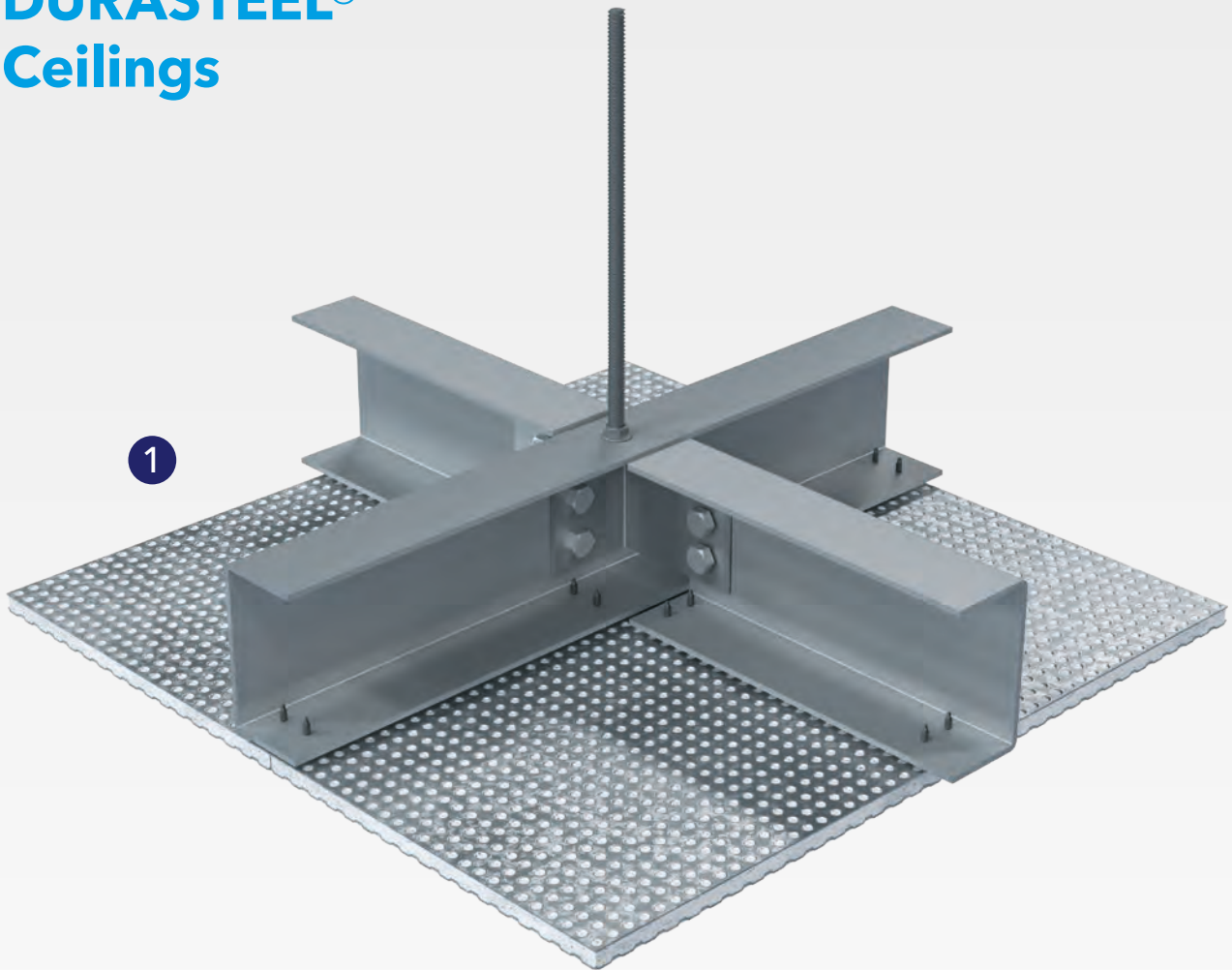

DURASTEEL® CEILINGS PROVIDE FIRE PROTECTION FOR UP TO 240 MINUTES AND CAN BE BUILT AS INSULATED AND UNINSULATED BARRIERS.

1 DURASTEEL® Suspended Ceiling Membrane (E 240 - Integrity Only) Fire from above or below

Fire resistance	240 minutes integrity only
Channel (minimum)	80mm x 60mm x 3mm
Overall depth	89.5mm
Weight (nominal)	27kg/m ²

Note: All drawings are for illustrative purpose only.

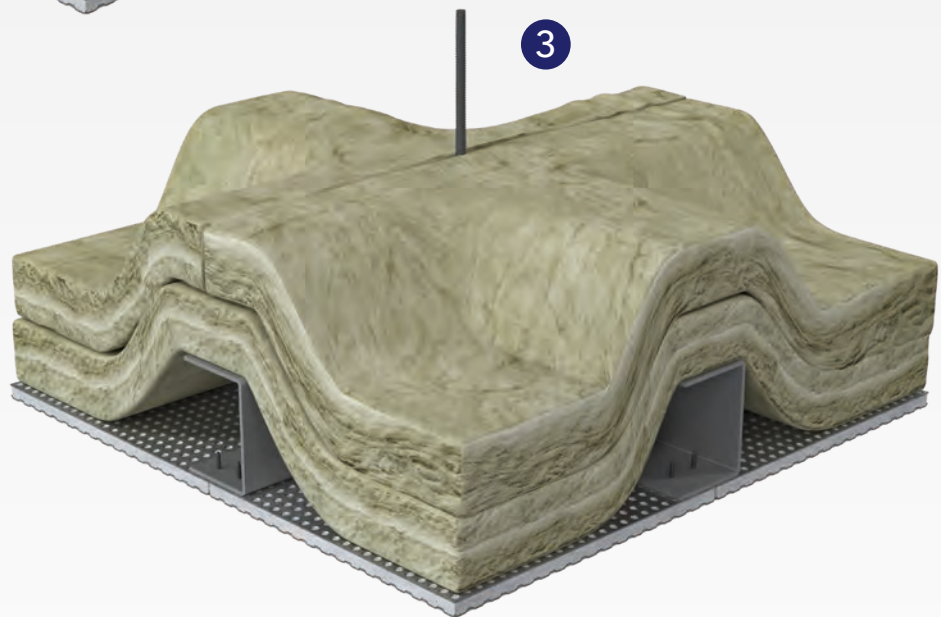
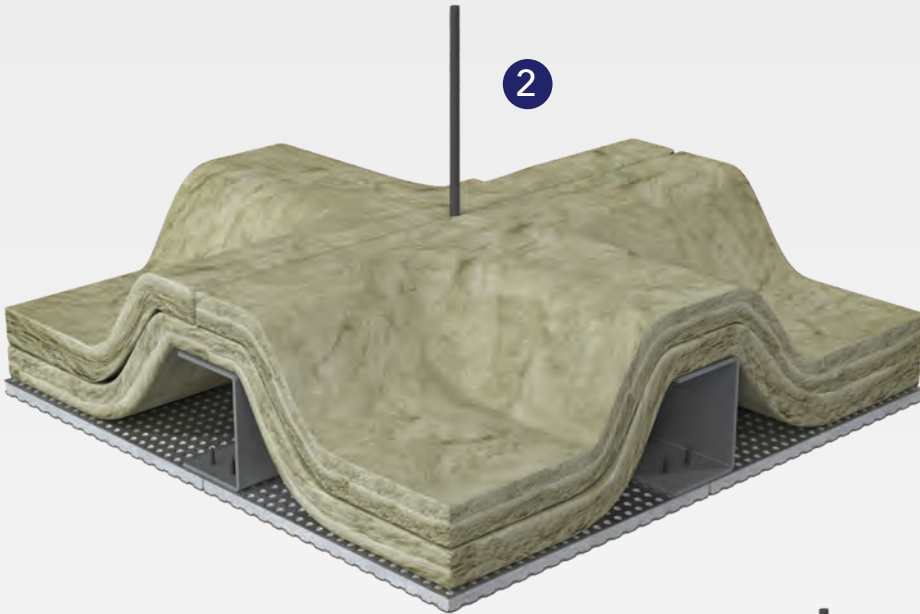

2 DURASTEEL® Suspended Ceiling Membrane
(E 240 - EI 60) Fire from above and below

Fire resistance	240 minutes integrity 60 minutes insulation
Channel (minimum)	80mm x 60mm x 3mm
Overall depth	140mm
Weight (nominal)	34kg/m ²

3 DURASTEEL® Suspended Ceiling Membrane
(E 240 - EI 120) Fire from above and below

Fire resistance	40 minutes integrity 120 minutes insulation
Channel (minimum)	80mm x 60mm x 3mm
Overall depth	170mm
Weight (nominal)	39kg/m ²

4

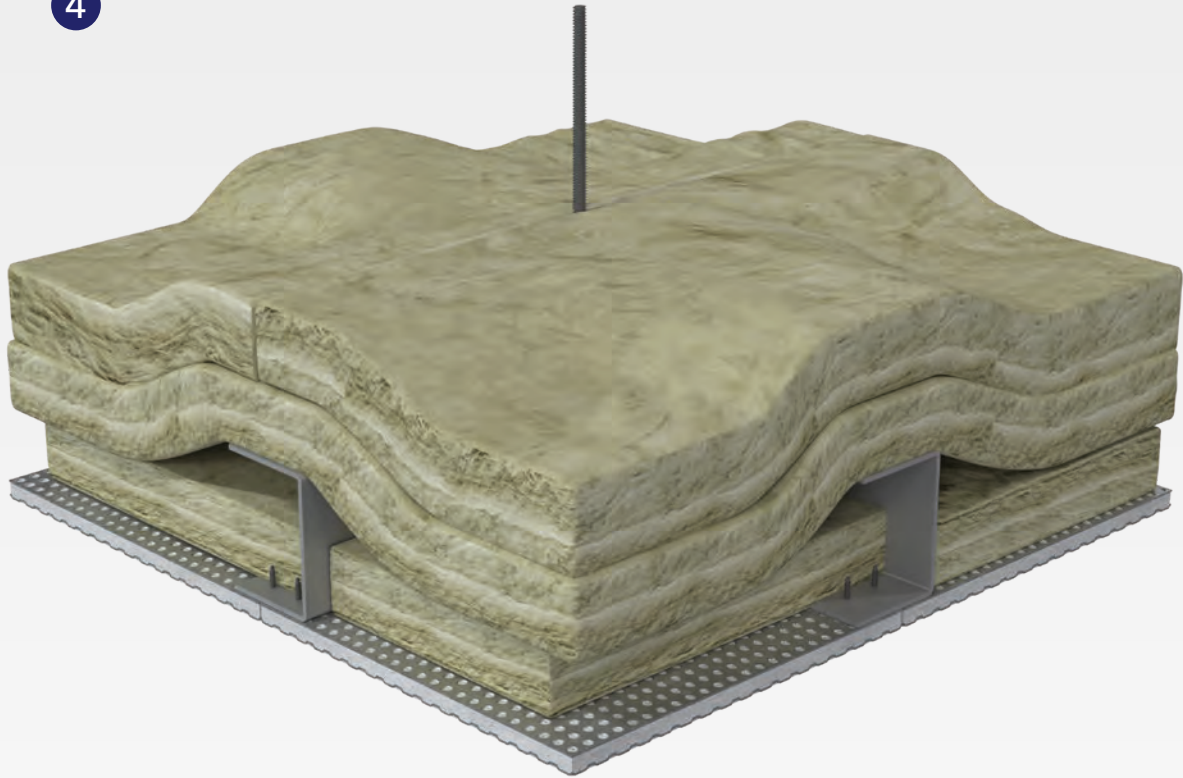

4 DURASTEEL® Suspended Ceiling Membrane
(EI 240) Fire from above and below

Fire resistance	240 minutes integrity and insulation
Channel (minimum)	80mm x 60mm x 3mm
Overall depth	170mm
Weight (nominal)	45kg/m ²

Note: All drawings are for illustrative purpose only.

5

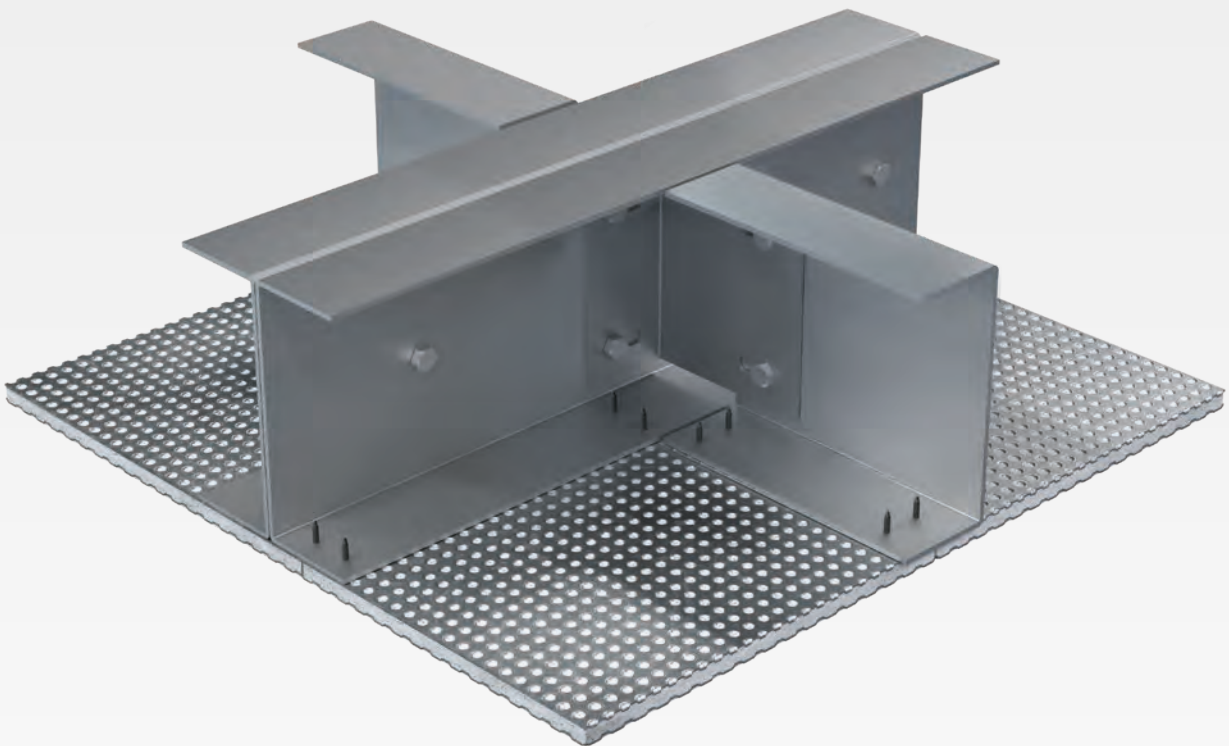

5 DURASTEEL® Self-Supporting Ceiling Membrane
(E 240) Fire below only

Fire resistance	240 minutes integrity
Channel (minimum)	150mm x 60mm x 3mm back to back
Maximum span	4400mm
Overall depth	160mm
Weight (nominal)	27kg/m ²

DURASTEEL® Ducts

DURADUCT® LT Ductwork System
 Certificate: Warrington Certifire CF 480

DURASTEEL® DUCTS PROVIDE FIRE PROTECTION FOR UP TO 240 MINUTES AND CAN BE BUILT AS INSULATED AND UNINSULATED DUCT SYSTEMS.

DURADUCT® LT is a fast track and economical DURASTEEL® based fire resisting ductwork solution which combines the air flow and wipe down characteristics of standard galvanized steel ductwork with the armour plated comfort of 'fit and forget' DURASTEEL®.

The DURADUCT® LT system is manufactured by approved ductwork contractors and can be delivered to site with minimal site handling.

DURADUCT® LT is tried and tested in ductwork solutions for natural ventilation ducting, mechanical ventilation ducting, natural smoke vents, mechanical smoke vents, fire rated pressurisation ductwork and kitchen extract ducting.

Table 1: Ductwork insulation matrix – Promat DURADUCT® LT

Powered ventilation / Natural ventilation / Smoke extraction / Kitchen extract All duct work is tested / assessed to BS 476: Part 24: 1987 (ISO 6944-1985) Type A duct - External fire condition Type B duct - Internal fire condition					
Natural ventilation / Powered ventilation / Smoke extract					
Minutes	Stability	Integrity	Stone wool insulation		
			Type A or B duct – 300°C smoke temperature	Type A duct – 1000°C+	Type B duct – 1000°C+
30	Yes	Yes	LT Only	LT Only	LT Only
60	Yes	Yes	LT Only	LT + 30mm of 60kg/m ³	LT + 50mm of 60kg/m ³
120	Yes	Yes	LT Only	LT + 50mm of 60kg/m ³	LT + 80mm of 140kg/m ³
180	Yes	Yes	LT Only	LT + 50mm of 140kg/m ³	LT + 100mm of 140kg/m ³
240	Yes	Yes	LT Only	LT + 65mm of 165kg/m ³	LT + 120mm of 140kg/m ³
Kitchen extract:					
When main fire risk is from in to out					
Type B duct, internal fire condition, use the above table for powered ventilation/smoke extract.					
Where main fire risk is from out to in					
Type A duct, external fire condition at 1,000°C+ use the table below.					
Minutes	Stability	Integrity	Stone wool insulation		
			Type A duct – 1000°C+		
60	Yes	Yes	LT + 50mm of 165 kg/m ³		
120	Yes	Yes	LT + 90mm of 165 kg/m ³		

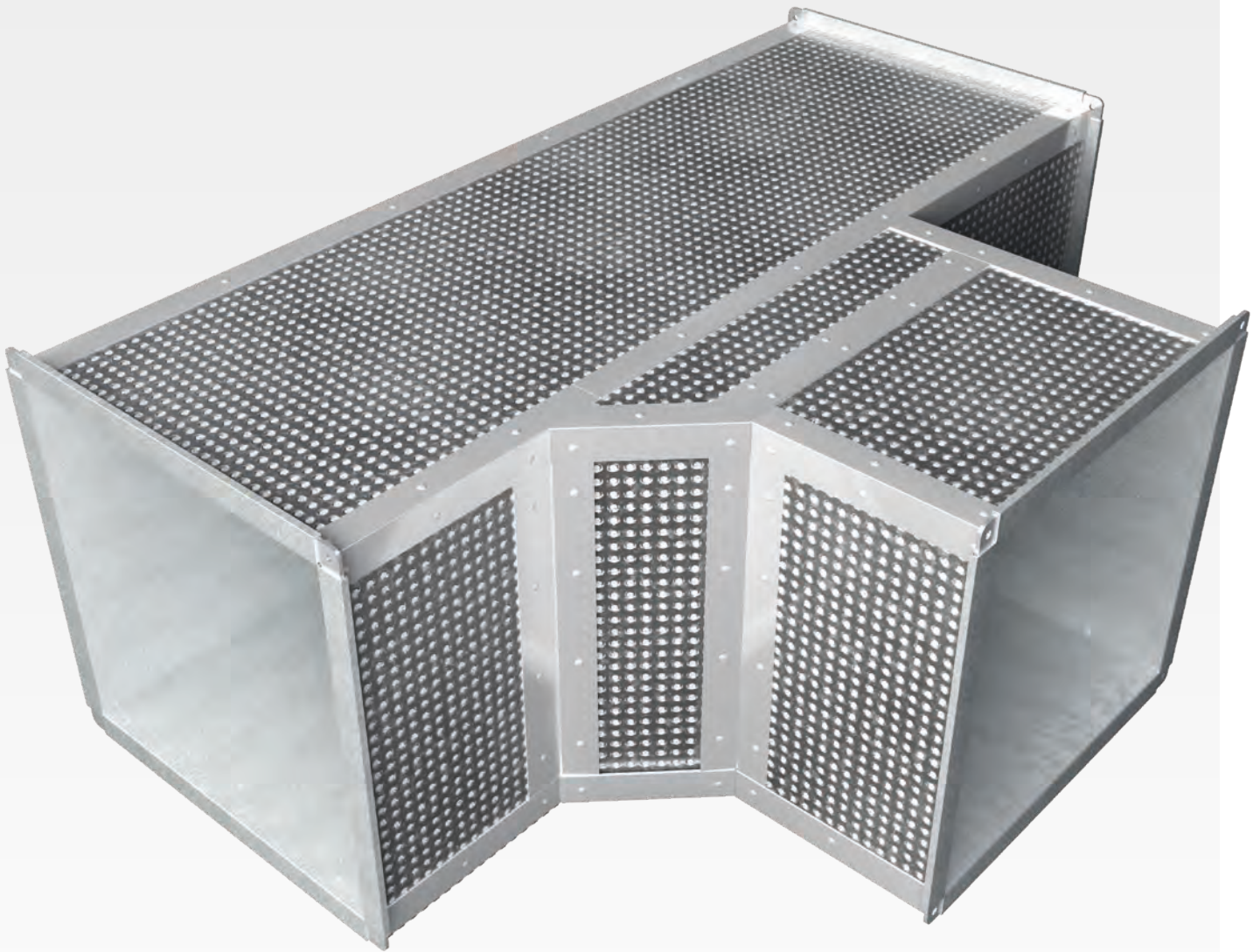

Note: All drawings are for illustrative purpose only.

DURASTEEL® Ducts

DURADUCT® SMT Ductwork System
Certificate: Warrington Certifire CF480

**UP TO 240 MINUTES STABILITY,
INTEGRITY AND INSULATION FIRE
RESISTANCE IN ACCORDANCE TO
BS 476: PART 24: 1987**

Promat DURADUCT® SMT Fireblast has been tested to provide high levels of blast and fire protection making the system uniquely suitable for potentially explosive environments such as electrical transformer and switch gear rooms.

Promat DURADUCT® SMT is also tried and tested in ductwork solutions for smoke control, smoke exhaust, fresh air ventilation, kitchen extraction, fire protection of building services, pressurisation riser shafts, lift-shaft protection and protection of power cables and services.

Table 2: Ductwork insulation matrix – Promat DURADUCT® SMT

Powered ventilation / Natural ventilation / Smoke extraction / Kitchen extract					
All duct work is tested / assessed to BS 476: Part 24: 1987 (ISO 6944-1985)					
Type A duct - External fire condition Type B duct - Internal fire condition					
Natural ventilation / Powered ventilation / Smoke extract					
Minutes	Stability	Integrity	Stone wool insulation		
			Type A or B duct – 300°C smoke temperature	Type A duct – 1000°C+	Type B duct – 1000°C+
30	Yes	Yes	SMT Only	SMT Only	SMT Only
60	Yes	Yes	SMT Only	SMT + 30mm of 60kg/m ³	SMT + 50mm of 60kg/m ³
120	Yes	Yes	SMT Only	SMT + 50mm of 60kg/m ³	SMT + 80mm of 140kg/m ³
180	Yes	Yes	SMT Only	SMT + 50mm of 140kg/m ³	SMT + 100mm of 140kg/m ³
240	Yes	Yes	SMT Only	SMT + 90mm of 165kg/m ³	SMT + 120mm of 140kg/m ³

Notes:

- 1) Where LT Only / SMT Only no insulation is required.
- 2) It is normally required to satisfy all the relevant performance criteria of stability, integrity and insulation. However, if no combustible materials or personnel could be in contact with the duct the Approval Authority may accept a reduced insulation performance.

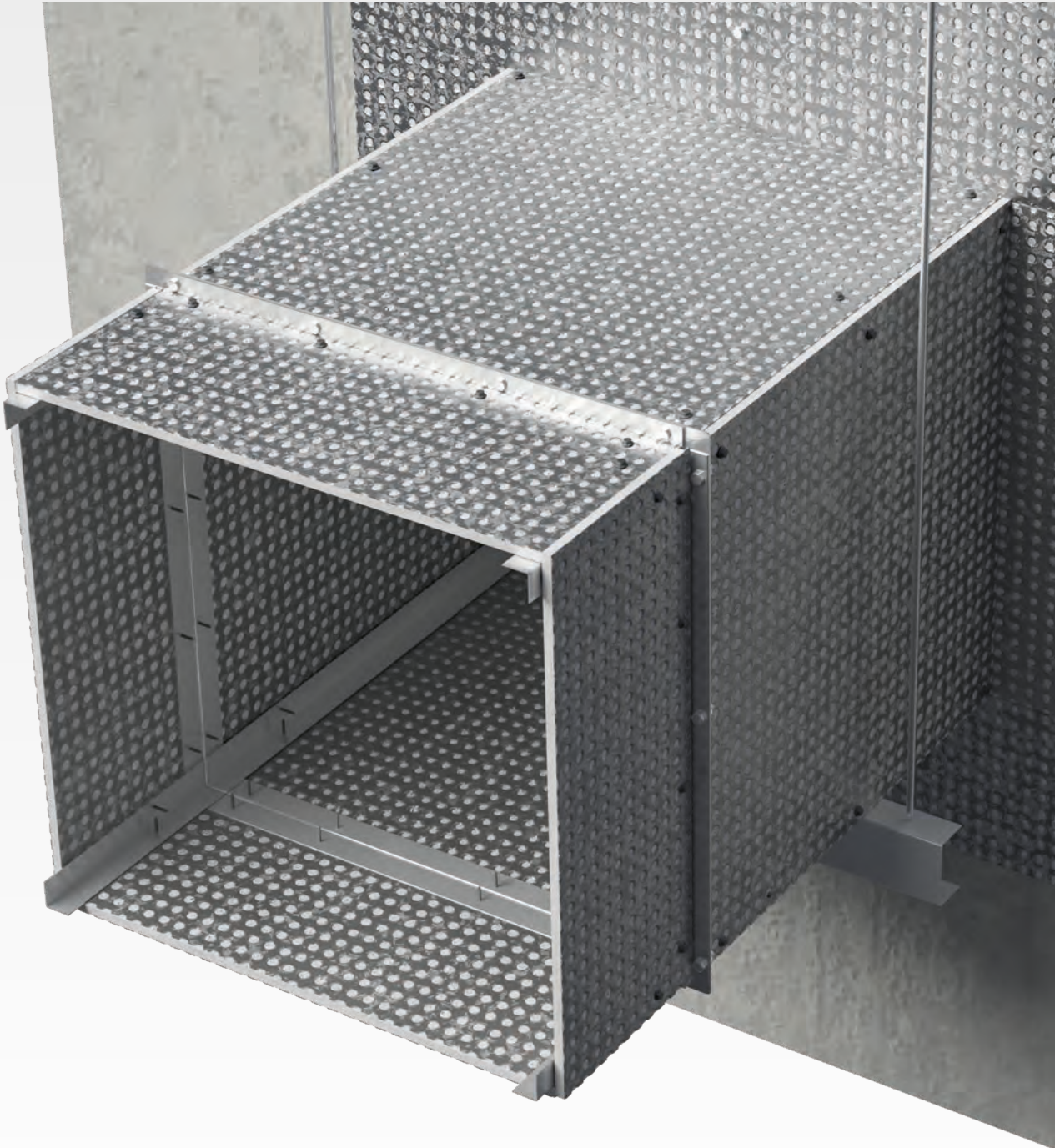

Note: All drawings are for illustrative purpose only.

DURASTEEL® Doors

Promat DURAFIRE® DD 120/240
Certificate: Certifire CF 418

The Promat DURAFIRE® DD door range covers single and double leaf constructions for internal and external use. Each door set can be built to an exact specification, enabling virtually any shape or size to be created.

Vision panel options are applicable for the entire Promat DURAFIRE® DD range.

The Promat DURAFIRE® DD range of hinged products are certified to BS 476: Part 22: 1987 for up to 240 minutes integrity.



Table 3: Fire performance

Configurations	Period of fire resistance (minutes)	Maximum door leaf height (mm)	Maximum door leaf width (mm)
DD 120 single-acting, single leaf – latched	240	2500	1050
DD 120 single-acting, double leaf – latched	240	2500	1050
DD120 single-acting, single leaf – three way shoot bolt mechanism	240	3000	1100
DD 120 single-acting, double leaf – three way shoot bolt mechanism on one leaf with shoot bolts to inactive leaf	240	3000	1100
DD240 single-acting, single leaf – three way shoot bolt mechanism	240	2400	1100
DD 240 single-acting, double leaf – three way shoot bolt mechanism on one leaf with shoot bolts to inactive leaf	240	2400	1100
DD 240 single-acting, double leaf – three way shoot bolt mechanism on one leaf with shoot bolts to inactive leaf	120	3000	1100

Note: DD 240 door leaves satisfy the mean temperature rise requirement of BS 476: Part 22: 1987 for 60 minutes



Note: All drawings are for illustrative purpose only.

Total Customer Support

Promat are committed to providing the highest level of technical expertise and support from the start of a fire safety project through its completion. We work with specifiers, architects, clients, project managers and contractors to ensure the appropriate solution is specified.

Support services include:

- Dedicated industry-specific specialist advice
- Development of working drawings
- Regular site inspections
- Expert guidance, drawing on the experience of the DURASTEEL® team, gained from years of dealing with commercial and public sector projects
- CAD drawings and a wealth of relevant technical data, information, accreditations, approvals, test reports and calculation tools
- Dedicated project specification packs
- RIBA approved CPD training schemes.

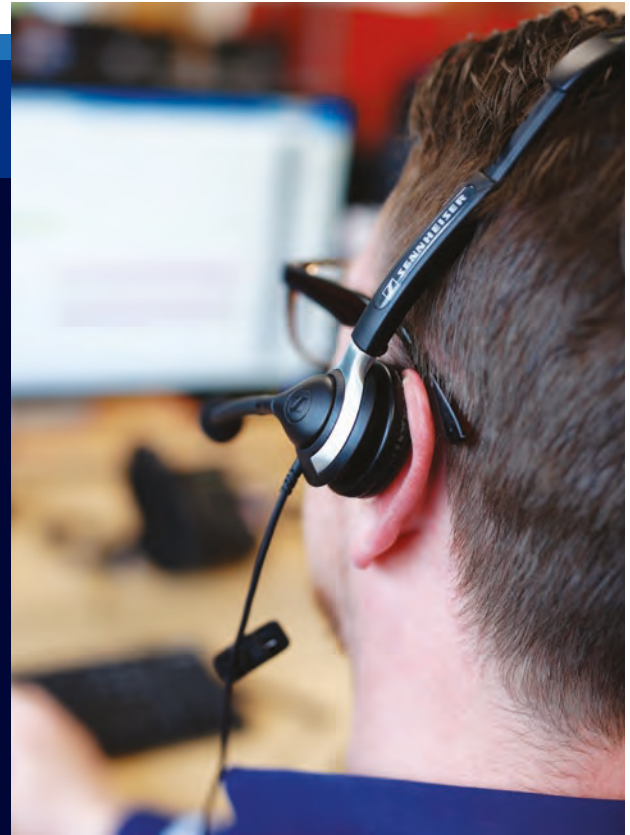

We understand that designing and building a passive fire protection solution is often not an easy task.

We can help you to interpret your local regulations and assess the risks in your building project that demand a reliable fire safety solution.

We can provide you with a full technical report and all the supporting documents you need to finalise your design and start the building process.

We offer you technical support and practical advice to deliver a perfect fire safety job.

Do not hesitate to contact us...

@ technical.promat@etexbp.co.uk

📞 0800 145 6033



Approved Licensed Installer Network

DURASTEEL® is only installed by experienced and approved installers, who ensure the system is fitted correctly for its intended application. Every installation can be issued with a Certificate of Conformity with installation checked prior to issue.



Image: Courtesy of SBL Fire Solutions

Orderline

For placing orders, delivery enquiries and local stockists.

0800 373 636

fpsales@etexbp.co.uk

Technical Services

For technical support and advice.

0800 145 6033

technical.promat@etexbp.co.uk

Etex Building Performance Limited

Gordano House, Marsh Lane,
Easton-in-Gordano,
Bristol, BS20 0NE

01275 377 773

promat.com